

Forced-air warming blowers: An evaluation of filtration adequacy and airborne contamination emissions in the operating room

Mark Albrecht, BSME, MBA,^a Robert L. Gauthier, MD,^b Kumar Belani, MBBS, MS,^c Mark Litchy, ME,^d and David Leaper, MD, ChM, FRCS, FACS^e
Edina, and Eden Prairie, MN; and Cardiff, UK

Background: Forced-air warming (FAW) is widely used to prevent hypothermia during surgical procedures. The airflow from these blowers is often vented near the operative site and should be free of contaminants to minimize the risk of surgical site infection. Popular FAW blowers contain a 0.2- μm rated intake filter to reduce these risks. However, there is little evidence that the efficiency of the intake filter is adequate to prevent airborne contamination emissions or protect the internal air path from microbial contamination buildup.

Methods: Five new intake filters were obtained directly from the manufacturer (Bair Hugger 505, model 200708D; Arizant Healthcare, Eden Prairie, MN), and 5 model 200708C filters currently in hospital use were removed from FAW devices. The retention efficiency of these filters was assessed using a monodisperse sodium chloride aerosol. In the same hospitals, internal air path surface swabs and hose outlet particle counts were performed on 52 forced-air warming devices (all with the model 200708C filter) to assess internal microbial buildup and airborne contamination emissions.

Results: Intake filter retention efficiency at 0.2 μm was 93.8% for the 200708C filter and 61.3% at for the 200708D filter. The 200708D filter obtained directly from the manufacturer has a thinner filtration media than the 200708C filter in current hospital use, suggesting that the observed differences in retention efficiency were due to design changes. Fifty-eight percent of the FAW blowers evaluated were internally generating and emitting airborne contaminants, with microorganisms detected on the internal air path surfaces of 92.3% of these blowers. Isolates of *Staphylococcus aureus*, coagulase-negative *Staphylococcus*, and methicillin-resistant *S aureus* were detected in 13.5%, 3.9%, and 1.9% of FAW blowers, respectively.

Conclusion: The design of popular FAW devices using the 200708C filter was found to be inadequate for preventing the internal buildup and emission of microbial contaminants into the operating room. Substandard intake filtration allowed airborne contaminants (both viable and nonviable) to penetrate the intake filter and reversibly attach to the internal surfaces within the FAW blowers. The reintroduction of these contaminants into the FAW blower air stream was detected and could contribute to the risk of cross-infection. Given the deficiencies identified with the 200708C intake filter, the introduction of a new filter (model 200708D) with substantially lower retention efficiency is of concern.

Key Words: Surgical site infection; patient warming; laminar air flow; operating room environmental contamination; filtration.

Copyright © 2010 by the Association for Professionals in Infection Control and Epidemiology, Inc. Published by Elsevier Inc. All rights reserved. (*Am J Infect Control* 2010;■:1-8.)

From Augustine Biomedical and Design, Eden Prairie, MN^a; Anesthesia Specialty Services, Edina, MN^b; Department of Anesthesiology, University of Minnesota, Minneapolis, MN^c; CT Associates, Inc, Eden Prairie, MN^d; and Department of Wound Healing, Cardiff University, Cardiff, UK.^e

Address correspondence to Mark Albrecht, BSME, MBA, 6581 City West Parkway, Eden Prairie, MN 55408. E-mail: albre116@umn.edu.

Conflict of interest: David Leaper chaired the NICE guideline on SSI prevention and treatment, is a member of the Antimicrobial Resistance and Healthcare Associated Infection advisory committee in the UK, and has served as a consultant/paid lecturer to several healthcare companies in relation to SSI. Mark Albrecht is a researcher funded by Augustine Biomedical + Design. None of the other authors have any conflicts of interest to report.

0196-6553/\$36.00

Copyright © 2010 by the Association for Professionals in Infection Control and Epidemiology, Inc. Published by Elsevier Inc. All rights reserved.

doi:[10.1016/j.ajic.2010.06.011](https://doi.org/10.1016/j.ajic.2010.06.011)

Forced-air warming (FAW) has been widely adopted in clinical practice to prevent inadvertent hypothermia. This is based on the well-established benefits of normothermia during operative procedures, including reduced operative blood loss, improved wound healing, reduced duration of hospital stay, improved survival, and reduced rates of surgical site infection (SSI).¹⁻⁶ The airflow from these FAW devices is often vented into the sterile field adjacent to the operative site and ideally should be free of contaminants to minimize the risk of SSI. Popular FAW devices currently in widespread use contain a 0.2- μm rated intake filter to reduce this risk.⁷ However, we are not aware of any published evidence demonstrating sufficient efficiency of the intake filter to prevent airborne contamination emissions or to protect the internal air path from a buildup of microbial contamination.

Airborne contamination comprises all particulate matter suspended in the operating room (OR) air. Common forms include microbial-laden dust, fibers from theatre clothing and operative drapes, desquamated skin, and respiratory droplets.⁸⁻¹⁰ These contaminants are mobilized by air currents and have been shown to settle out of the air onto the operative site, contributing to the risk of a SSI through at least two likely mechanisms. Pathogenic contaminants can directly cause an SSI, and nonpathogenic contaminants can lead to an SSI through the formation of a nidus for microbial attachment and growth.¹¹ A high level of airborne contamination at the operative site is not necessary; the risk of a superficial or deep SSI increases exponentially in the presence of a foreign body, such as a hip or knee prosthesis.^{12,13}

To limit the associated risks of airborne contamination, OR ventilation is designed to meet a minimum filtration efficiency standard of 90%.¹⁴ For many contamination-sensitive operations, particularly in the orthopedic and cardiovascular fields, ORs routinely use high-efficiency particulate air (HEPA) ventilation for added protection. By definition, HEPA filtration meets minimum filtration efficiency standards of 99.97% at 0.3 μm . As mentioned previously, most FAW devices use a 0.2- μm rated intake filter to prevent the emission of airborne contamination. A filter's micron rating conveys no information about its quality, however. The key parameter is the "filtration efficiency," or "retention efficiency," at the stated micron rating. The manufacturers of FAW blowers do not disclose the filtration efficiency of their intake filters,⁷ making it difficult to evaluate the adequacy of FAW intake filters for preventing the mobilization of airborne contaminants in the OR. Furthermore, we recently identified a number of FAW devices that were emitting excessive levels of airborne contamination in an OR environment, apparently related to airborne contaminants penetrating the intake filter over a prolonged period.¹⁵

In terms of preventing a buildup of internal microbial contamination, the FAW blower intake filter has been deemed deficient by a number of researchers. Previous studies have routinely found microbial colonization inside the majority of sampled FAW blowers.¹⁶⁻¹⁸ One study repeatedly cultured microbes from the blower's airstream; the authors recommended placement of a distal hose end filter to reduce the risk of microbial emissions.¹⁶ Some other studies assessing settle plate colonization levels have not detected any significant differences with the use of FAW in the OR, however.¹⁹⁻²¹ The results of those studies are difficult to interpret, given that only a small number of FAW blowers were sampled and the fact that the investigators did not take into account the possibility that these FAW blowers might or might not have been

internally contaminated based on their hours of use and number of environmental exposures.

Because of the perceived infection risks, many ORs have been reluctant to use FAW to maintain normothermia.²² Air-free alternatives to FAW have been developed, including conductive mattresses and blankets that have been shown to be comparably effective in randomized clinical trials²³⁻²⁹ and do not pose a similar risk of airborne contamination. With the availability of these clinically validated alternatives, it is important to assess whether the design of FAW blowers is adequate for preventing airborne contamination emissions in the OR. Given the critical role of the intake filter in preventing contamination emissions and buildup within FAW blowers, the present study focused on (1) rating the retention efficiency of two popular types of pleated gas intake FAW filters, using industry filtration challenge standards; (2) assessing the performance of FAW filters in the environment of use (the OR), by isolating the filters from the FAW devices and challenging them on a special test fixture; (3) quantifying airborne contaminants in the effluent air stream that were generated downstream of the intake filter within the FAW blower; and (4) culturing the internal FAW blower internal air path surfaces for buildup of microbial contamination.

METHODS

Sampling Procedures

FAW blowers in the ORs of hospitals in the vicinity of Minneapolis and St Paul were sampled after hours to quantify the following:

1. Emission of airborne contamination from the distal air stream, recorded using a calibrated laser particle counter (Handilaz Mini; Particle Measuring Systems, Boulder, CO). Particle counts were taken within the intake and distal hose end airstreams. For the intake sample, the probe was placed 2-5 cm from the intake filter; for the distal sample, the probe was placed 2-5 cm inside the distal hose end. Three 1-minute 0.1-ft³ samples were taken at each location.
2. Performance of the intake filter in the OR environment, measured separately from the FAW blower using a portable test fixture that challenged the intake filter with ambient operating room air. The fixture consisted of a downstream vacuum (calibrated to draw 35 ft³/min of ambient operating room air through the filter), a mounting plate, and an internal particle sampling pitot tube located downstream of the filter in the center of the air channel before the vacuum. With the intake filter affixed to the fixture and the vacuum running, particle counts of a 0.1-ft³ sample volume were taken upstream and

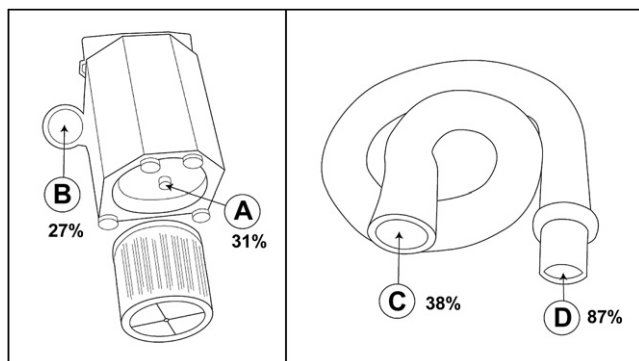

Fig 1. Detection rates for nonspecific microorganisms on FAW blower ($n = 52$) internal air path surfaces by swabbing location: (A) motor stack, (B) elbow, (C) proximal hose end, and (D) distal hose end.

downstream of the intake filter. For the upstream sample, the probe was placed 2-5 cm from the exposed filter media surface; for the downstream sample, the probe was coupled to the sampling pitot tube using a 7-cm tubing extension. Three samples were taken at each location.

- Microbial colonization of the internal air path surfaces, sampled using swabs moistened with Butterfield's buffer solution. Moistened swabs were rubbed against an $\sim 10\text{-cm}^2$ area of the following internal air path surfaces (Fig 1): exposed plastic surfaces of structure supporting the motor directly downstream of the intake filter, injection molded elbow connecting the proximal hose to the unit, and injection molded proximal (unit end) and distal (output end) hose fittings. Four control swabs, representing the swab set for a complete unit, were also obtained simultaneously and sent to the microbiology laboratory in a blinded fashion with the active samples. The control swabs were obtained by moistening the swab with Butterfield's buffer and placing the swab directly into its transport container.

Intake FAW blower filters were acquired for further testing both in new condition directly from the manufacturer (Arizant Healthcare, Eden Prairie, MN) and in used condition from FAW devices in use in ORs for quantification of intake filter retention efficiency, measured by challenging the filters through a range of monodisperse particle sizes (0.025-0.5 μm). An industry standard filtration test fixture used a blower and HEPA filtration to remove all ambient particulate from the challenge air. An atomizer (Quant Technologies, Blaine, MN) provided a polydisperse NaCl aerosol to an aerosol neutralizer (model 3077; TSI, Shoreview, MN), which used a krypton-85 radiation source to neutralize the particle charge distribution to Boltzmann equilibrium levels. An electronic classifier (model

3080; TSI) then selected a portion of the polydisperse NaCl aerosol based on its electronic mobility diameter, thereby producing a monodisperse NaCl aerosol. This monodisperse NaCl aerosol was injected into the challenge airstream. Upstream and downstream particle concentrations were measured simultaneously using two condensation particle counters (models 3772 and 3782; TSI). An air velocity meter (Dwyer Instruments, Michigan City, IN) was used to record the challenge airflow (range, 30-45 ft^3/min).

Assessments

Microbiological culturing and analysis were performed by PACE Analytical (Oakdale, MN). Assessments of intake filter retention efficiency were performed by CT Associates Inc (Eden Prairie, MN). Filter retention efficiency was calculated as the fraction of particles captured by the filter over a 5- to 10-minute challenge period in the industry standard filtration challenge test fixture. Retention efficiencies were measured for each filter at 6 monodisperse particle challenge sizes: 0.025 μm , 0.05 μm , 0.1 μm , 0.2 μm , 0.3 μm , and 0.4 μm ; some filters were challenged at a seventh particle size of 0.5 μm . Challenge concentrations varied from 85,000 to 1,100,000 particles/ ft^3 , depending on particle size. The most penetrating particle size (MPPS) was defined as the particle size at which the filter displayed a minimum retention efficiency.

Intake filter performance in the OR environment was assessed as the fraction of particles $>0.3 \mu\text{m}$ captured by the intake filter when challenged by ambient operating room air on the portable test fixture. A 6-minute challenge period was used for each filter, during which upstream and downstream measurements were performed sequentially. Reported values for upstream particles were calculated as the average particle concentration upstream of the intake filter. Similarly, reported values for downstream particles were calculated as the average particle concentration downstream of the filter.

Expected distal airstream particle emissions were calculated for each FAW blower by (1) computing the average concentration of $>0.3\text{-}\mu\text{m}$ particles in the intake airstream and (2) multiplying the average intake airstream particle concentration by the fraction of $>0.3\text{-}\mu\text{m}$ particles removed by the intake filter (as observed during intake filter performance testing). Intake airstream particle concentrations were measured over a 3-minute sampling period.

Deviations from expected distal airstream particle emissions were calculated for each FAW blower by subtracting the expected distal airstream particle concentration from the observed distal airstream concentration of $>0.3\text{-}\mu\text{m}$ particles. Distal airstream particle concentrations were measured over a 3-minute

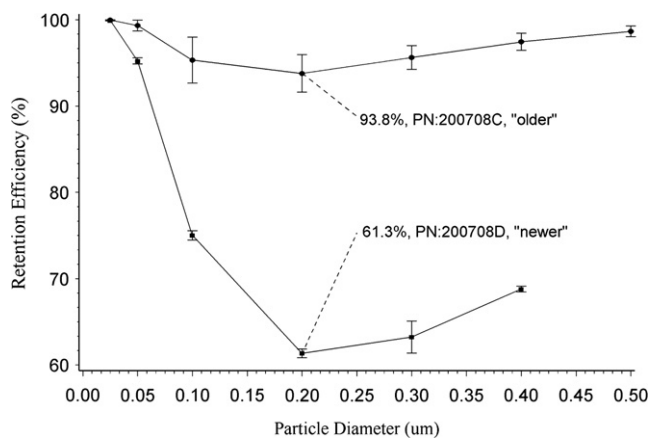

Fig 2. Mean retention efficiencies for intake filter models 200708C (n = 5) and 200708D (n = 5) with dispersion indices (\pm 1 standard deviation). For each filter, the efficiency rating at the most penetrating particle size is shown.

sampling period. The deviation from expected distal air-stream particle emission represents the quantity of particulate emission generated inside the FAW blower downstream of the intake filter.

The number of colony-forming units (CFUs) per swab was assessed as follows. Swabs were transported from the site in 5 mL of Butterfield's buffer on ice. The diluent and swab were vortexed in a transport container for 30 seconds. In duplicate, 1 mL of the sample was pipetted into a Petri dish, and 25 mL of molten 45°C tryptic soy agar was added to form a nonselective growth medium. After incubating for 48-72 hours at $36.0 \pm 0.1^\circ\text{C}$, the dishes were inspected for microorganism growth, with each individual colony counted as a single CFU. The reported number of CFUs per swab represents the average colony counts recorded between the two Petri dishes multiplied by a conversion factor of 5. The reported counts for the distal hose, proximal hose, elbow, and motor stack are the CFUs reported for the single swab used at each location (Fig 1). Combined CFUs per FAW blower are the sum of the CFUs reported at each of the 4 swabbing locations.

The presence of specific microorganisms was assessed for each swab through enriching and incubating the remaining diluent (24 hours at $36.0 \pm 0.1^\circ\text{C}$), followed by testing for *Staphylococcus aureus* and coagulase-negative *Staphylococcus* (CoNS) using mannitol salt agar and for methicillin-resistant *S aureus* (MRSA) using CHROMagar (BD, Franklin Lakes, NJ). No other *Staphylococcus* species were identified.

Statistical analysis

FAW blowers with significant deviations from expected distal air stream particle emissions were

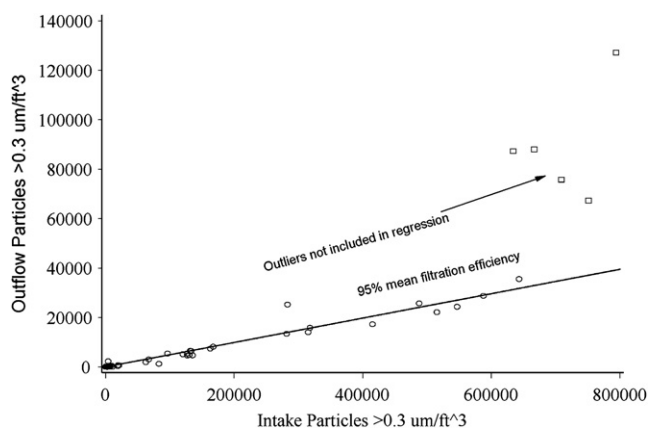

Fig 3. Intake filter performance in the surgical environment of use as assessed with the OR room challenge fixture (not shown). Individual intake filter performance values (n = 52) are displayed, along with a fitted no-intercept linear regression model.

identified using a variance-weighted analysis of covariance model with particle outflow concentration as the response. Predictors included intake particle concentration as a covariate and FAW blower serial number and treatment (filter isolated or filter on FAW blower) as fixed effects. Significant treatment differences were identified as those with a P value $< .05$ (two-tailed).

Pearson correlation coefficients were calculated to assess the linear correlation between FAW blower particulate emissions (generated downstream of the intake filter) and CFUs detected for each swabbing location (distal, proximal, elbow, motor stack, and combined). The P value represents the two-tailed probability that the Pearson correlation coefficient is equal to 0.

RESULTS

A total of 52 FAW blowers (Bair Hugger, model 505; Arizant Healthcare, Eden Prairie, MN) were sampled in their surgical environment of use (ORs) from 11 hospitals. Only OR-dedicated FAW blowers were sampled. Sampling was conducted in 38 separate ORs, in which FAW blowers were sometimes moved to a common OR for sampling that shared the same central hospital ventilation as the other ORs. The distribution of ambient OR air quality provided by the ventilation system differed greatly by hospital (Figs 3 and 4), with ventilation quality ranging from 0 to 800,000 $>0.3\text{-}\mu\text{m}$ particles/ ft^3 centered on a median of 8,600 $>0.3\text{-}\mu\text{m}$ particles/ ft^3 ; upper and lower quartiles were 130,000 and 3,600 $>0.3\text{-}\mu\text{m}$ particles/ ft^3 , respectively.

Intake filter retention efficiency

The retention efficiencies for the model 200708C (n = 5) and 200708D (n = 5) filters differed significantly,

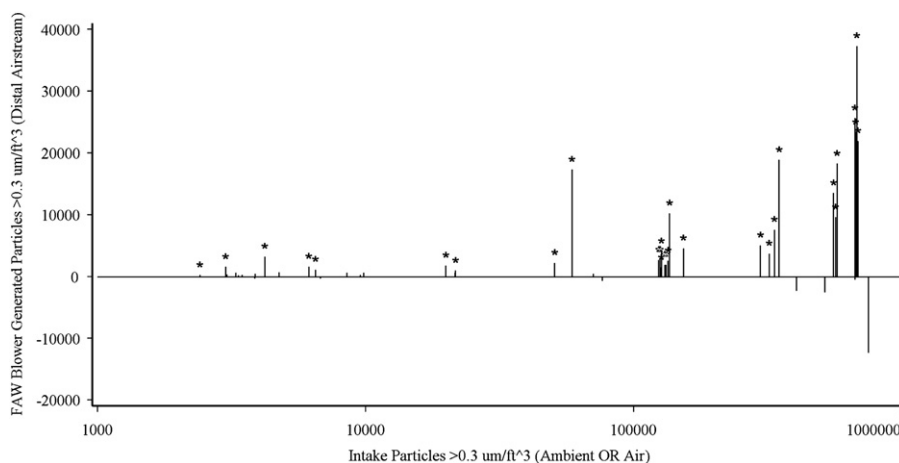

Fig 4. FAW blower distal hose airflow particulate emissions above (or below) expected levels based on the measured efficiency of each filter and intake air particulate levels. *FAW blowers with significant particulate emissions exceeding the expected level ($P < .05$).

with mean reported retention efficiency values of 93.8% and 61.3%, respectively, at an MPPS of 0.2 μm (Fig 2). A visual inspection of both filters revealed a thinner filtration media in the 200708D filter, a difference that was especially apparent when both filter models were held up to a light source.

Intake filter performance in the surgical environment

Of the 52 model 200708C model intake filters that were challenged with OR air, 47 appeared to have consistent efficiencies within the expected range of operation (Fig 3), and 5 sampled in “dirtier” environments appeared to have lowered filtration efficiencies. A linear no-intercept regression model fitted to the data for the 47 intake filters demonstrating consistent performance identified a filtration efficiency of 95% for $>0.3\text{-}\mu\text{m}$ particles as the best fit.

FAW blower-generated particles

Distal hose end air stream particle emissions were well above what would be expected for the majority of FAW blowers ($n = 30$) based on reported intake filter performance. Deviations from expected distal particle emissions for each FAW blower—a quantity based on measured intake filter performance and distal particle emissions for each individual unit—revealed that 58% of FAW blowers were generating significant levels of $>0.3\text{-}\mu\text{m}$ particles, up to 35,000 particles/ ft^3 downstream of the intake filter (Fig 4). The magnitude of FAW blower particle generation was loosely correlated with ambient OR air particulate concentrations.

FAW blower air path colonization

Air path swabs from FAW blowers revealed the presence of viable microorganisms in 92% of the blowers (Fig 1), with the heaviest growth reported on the internal air path surfaces of the distal hose end (Fig 5). Isolates of *S aureus*, CoNS, and MRSA were detected inside 13.5%, 3.9%, and 1.9% of the FAW blowers, respectively. Pearson correlation coefficients indicated a lack of correlation between blower-generated particles and internal levels of microbial colonization for the combined measurement ($P = .09$) as well as all individual swab locations (distal, $P = .09$; proximal, $P = .31$; elbow, $P = .26$; motor, $P = .99$). Microbes were detected on the nonspecific growth medium for a small proportion of control samples (9%); all microorganism-specific control samples were negative.

DISCUSSION

Our results suggest that popular FAW devices in current use are of questionable design with regard to preventing airborne contamination emissions into the OR and possibly the surgical field. Inadequate FAW blower intake filtration (93.8% for the model 200708C filter and 61.3% for the model 200708D filter) resulted in an internal buildup of microbial contamination within the majority of FAW blowers (92%) on inaccessible air path surfaces. The majority of FAW blowers (58%) also were found to be internally generating airborne contamination downstream of the protective intake filter. This might have been related to the release of built-up contaminants acquired during previous periods of use in environments with elevated levels of ambient airborne contaminants. This is the first study focusing on

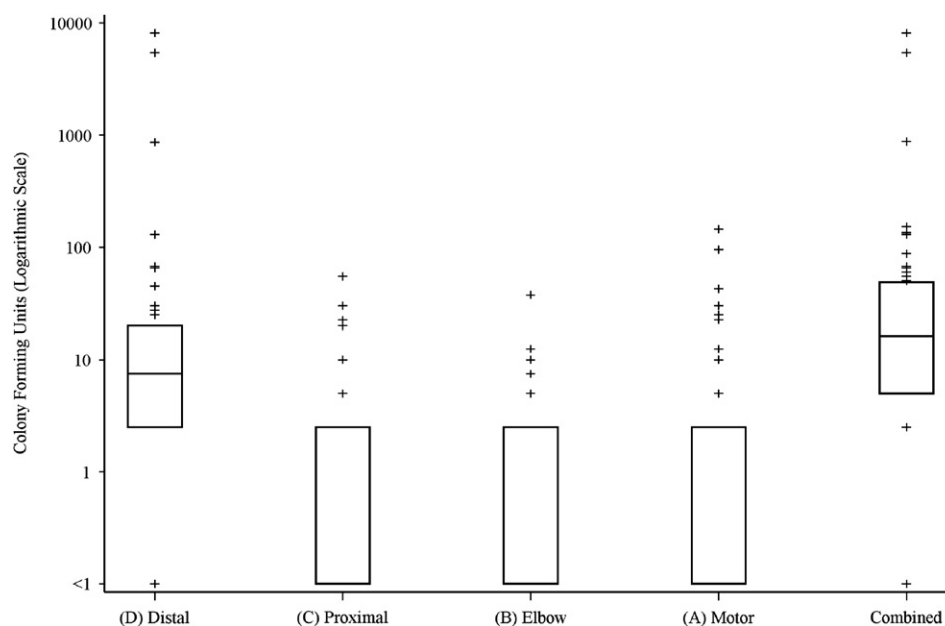

Fig 5. Number of CFUs detected by sampling location, reported as 25th, 50th, and 75th quantiles with marked outliers.

assessing FAW blower intake filter performance and its relationship to FAW blower-generated airborne contamination.

We felt that it was important to characterize the intake filter separate from the FAW blower, given that previous research identified elevated levels of contamination emission from a number of FAW blowers,¹⁵ but the source of this contamination could not be conclusively identified as being downstream of the intake filter. By characterizing the performance of each FAW blower intake filter in its environment of use (the OR), we were able to determine the expected particle emissions from FAW blowers and isolate emissions in excess of this expected value as being introduced downstream of the intake filter within the FAW blower. However, this study was limited in its ability to identify the exact composition of these emitted contaminants, because we identified only selected microorganisms through swabbing and did not collect particulate samples for assessment through microscopy. Nevertheless, previous research, reported intake filter retention efficiencies, and swabbing results provide some general information regarding the source of such contaminants.

Previous studies of the size distribution of airborne contaminants upstream and downstream of FAW blowers concluded that air leaks on the intake side were an unlikely source of contamination.¹⁵ This leaves the wear-and-tear of moving components or the release of built-up contaminants as the most likely sources. The disintegration of moving components is an unlikely source, given that the generation of contamination was not uniform for blowers with similar

internal components. This trend toward nonuniformity is apparent in Figure 4 if several relationships are considered. First, FAW blowers with similar levels of intake particulate challenge typically belong to the same hospital. Second, these FAW blowers within a single hospital generally come from the same manufacturing lot and thus have similar internal components. Finally, based on intake particulate challenge results, these groups of blowers from similar lots would be expected to exhibit uniform trends of contamination generation. This correlation is not apparent in Figure 4, however. In contrast, the release of built-up contaminants appears to be a probable cause based on reported FAW blower intake filter retention efficiencies.

All of the FAW blowers evaluated in the OR from this sample population used the model 200708C intake filter, which had a reported retention efficiency of 93.8% when challenged by a specific size of particulate (0.2 μm). In addition, performance data suggest that most of the 200708C filters performed near or within specifications in the OR when challenged with ambient air (95% at $>0.3 \mu\text{m}$). However, this level of intake filtration implies that approximately 5%-7% of ambient airborne contaminants pass through the intake filter and into the FAW blower. These airborne particles (both viable and nonviable) are likely to reversibly attach to the FAW blower's internal plastic air path surfaces, particularly because plastic surfaces tend to develop an attractive static charge in the presence of a particulate-laden airflow.³⁰

As such, the nature of contaminants contained in the FAW blower is likely to depend on both the past and current environments of use. The typical location for FAW

blowers in the OR tends to be near the floor by the head of the operating table. Movements of the surgical staff and patient have been shown to generate large quantities of desquamated skin cells, as much as 10% of which have been shown to carry viable microorganisms.^{9,31} These shed skin cells have a wide particle size distribution, extending well below 5 μm due to flake fragmentation,^{32,33} thus, a large portion of these skin cells are small enough to become buoyant and follow the downward nature of the laminar air flow toward the FAW blower intake. The efficiency of the intake filter suggests that a large number of these potentially pathogen-carrying cells could penetrate the filter and build up on the FAW blower's internal air path surfaces. This mechanism of airborne skin cell "seeding" is a likely explanation for the 92% internal colonization rate. This is further supported by the finding that approximately 15% of reported isolates were skin-specific organisms, namely *S aureus* and CoNS. In addition, FAW blowers often are moved between clean-air OR environments and the recovery room, a practice that might exacerbate the airborne contamination to which these FAW blowers are exposed. This relationship between environmental exposure and the degree of FAW blower contamination generation is illustrated in Figure 4, where higher degrees of contamination generation in ORs with higher ambient particulate levels.

The concept of "seeding" also presents the possibility of microbe growth and aerosolization from internal FAW blower surfaces. Deposited contaminants may act as the nutrient source for sustaining microbe growth. However, Pearson correlation coefficients demonstrated no conclusive relationships between detected CFU counts and emitted contaminant levels, suggesting that a large portion of emitted contaminants were non-viable in nature. Our results warrant future research into this matter.

Nevertheless, relevant clinical risks are related to the potential release of these airborne contaminants from FAW blowers in the vicinity of the surgical site. Although our findings do not establish a direct link between FAW and increased SSI rates, they do raise awareness of the potential risks associated with FAW use. Further, our results and those of others¹⁵⁻¹⁸ demonstrate appreciable microbial contamination on the internal air path surfaces of FAW blowers, consisting of common pathogenic isolates (*S aureus*, CoNS, MRSA) that are typically involved in superficial and deep SSIs.¹¹ These isolates, as free-floating bacteria, are commonly found in ORs and have a particle size range of 0.5-4 μm ,³⁴ which corresponds to the size distribution of FAW blower-borne contaminants detected in this study. In prosthetic surgery, all of the identified organisms are associated with appreciable morbidity and mortality, and their presence could lead to the

need for revision or removal of an infected prosthetic joint.³⁵ Moreover, the potential for the mobilization and release of built-up pathogenic contaminants suggests that FAW blowers might increase the risk of cross-contamination between operations; for example, one study implicated FAW blowers as the causative factor in an outbreak of *Acinetobacter baumannii*.¹⁸

Our results point to 3 primary design inadequacies of FAW blowers that contribute to the buildup and release of contaminants. First, the inaccessible nature of the internal FAW blower air path surfaces prevent regular cleaning and decontamination. This is in contrast to guidelines from the European Union Medical Device Directives, US Food and Drug Administration, and Health Canada regarding reusable medical equipment that either require or recommend manufacturers to offer a means for decontamination.³⁶⁻³⁸ Second, current FAW blower intake filtration measures are inadequate to prevent the buildup of microorganisms on internal air path surfaces. Finally, the design of current FAW blowers does not include an outlet filter that could prevent the emission of contaminants into the OR. FAW device manufacturers should be encouraged to redesign FAW blowers such that internal surfaces are accessible for decontamination and that true HEPA filtration (>99.97% at 0.3 μm) is offered as a protective measure at the intake and hose outlet. In the meantime, hospitals and care providers might consider periodic sterilization procedures for reconnectable components of their FAW machines. In addition, the introduction of a new filter (model 200708D) with lower filtration efficiency (61.3%) in popular FAW blower models is of concern.

In conclusion, this study highlights the potential risks of intraoperative surgical site contamination when FAW devices are used in clean OR environments. These risks may be elevated in contamination-sensitive operations, such as prosthetic elective surgery, that demand laminar HEPA airflow ORs. The need to avoid inadvertent hypothermia is now well recognized³⁹ and is part of the mandatory checklist in the World Health Organization's "Safe Surgery Saves Lives" campaign.⁴⁰ Our findings suggest that it would be prudent to add HEPA filtration to the intake and outlet of FAW blowers to reduce the risk of emission and mobilization of contaminants in the OR environment. Alternatively, air-free warming technologies, such as conductive fabric mattresses and blankets,²³⁻²⁹ that can be easily decontaminated should be considered.

References

1. Schmied H, Kurz A, Sessler DI, Kozek S, Reiter A. Mild hypothermia increases blood loss and transfusion requirements during total hip arthroplasty. *Lancet* 1996;347:289-92.

2. MacFie CC, Melling AC, Leaper DJ. Effects of warming on healing. *J Wound Care* 2005;14:133-6.
3. Kurz A, Sessler DI, Lenhardt R. Study of Wound Infection and Temperature Group. Perioperative normothermia to reduce the incidence of surgical wound infection and shorten hospitalization. *N Engl J Med* 1996;334:1209-15.
4. Bush HL, Hydo LJ, Fischer E, Fantini GA, Silane MF, Barie PS. Hypothermia during elective abdominal aortic aneurysm repair: the high price of avoidable morbidity. *J Vasc Surg* 1995;21:392-400.
5. Mahoney CB, Odom J. Maintaining intraoperative normothermia: a meta-analysis of outcomes with costs. *J Am Assoc Nurse Anesth* 1999;67:155-63.
6. Kumar S, Wong PF, Melling AC, Leaper DJ. Effects of perioperative hypothermia and warming in surgical practice. *Int Wound J* 2005;2:193-204.
7. Bair Hugger therapy: warming units and accessories. Available from: <http://www.arizant.com/us/bairhuggertherapy/warmingunits>. Accessed January 22, 2010.
8. Davies RR, Noble WC. Dispersal of bacteria on desquamated skin. *Lancet* 1962;2:1295-7.
9. Noble WC. Dispersal of skin microorganisms. *Br J Dermatol* 1975;93:477-85.
10. Noble WC, Habbema JD, van Furth R, Smith I, de Raay C. Quantitative studies on the dispersal of skin bacteria into the air. *J Med Microbiol* 1976;9:53-61.
11. Mangram AJ, Horan TC, Pearson ML, Silver LC, Jarvis WR. Centers for Disease Control and Prevention, Hospital Infection Control Practices Advisory Committee. Guideline for prevention of surgical site infection, 1999. *Am J Infect Control* 1999;27:97-132.
12. Elek SD, Conen PE. The virulence of *Staphylococcus pyogenes* for man: a study of the problems of wound infection. *Br J Exp Pathol* 1957;38:573-86.
13. Lidwell OM, Lowbury EJ, Whyte W, Blowers R, Stanley SJ, Lowe D. Bacteria isolated from deep joint sepsis after operation for total hip or knee replacement and the sources of the infections with *Staphylococcus aureus*. *J Hosp Infect* 1983;4:19-29.
14. Sehulster L, Chinn RYV. Guidelines for environmental infection control in healthcare facilities: recommendations of CDC and the Healthcare Infection Control Practices Advisory Committee (HICPAC). *MMWR Recomm Rep* 2003;52(RR-10):1-42.
15. Leaper D, Albrecht M, Gauthier R. Forced-air warming: a source of airborne contamination in the operating room? *Orthop Rev* 2009;1:e28.
16. Avidan MS, Jones N, Ing R, Khoosal M, Lundgren C, Morrell DF. Convection warmers—not just hot air. *Anaesthesia* 1997;52:1073-6.
17. Baker N, King D, Smith EG. Infection control hazards of intraoperative forced air warming. *J Hosp Infect* 2002;51:153-4.
18. Bernards AT, Harinck HJ, Dijkshoorn L, van der Reijden TJK, van den Broek PJ. Persistent *Acinetobacter baumannii*? Look inside your medical equipment. *Infect Control Hosp Epidemiol* 2004;25:1002-4.
19. Huang JKC, Shah EF, Vinodkumar N, Hegarty MA, Greatorex RA. The Bair Hugger patient warming system in prolonged vascular surgery: an infection risk? *Crit Care* 2003;7:R13-6.
20. Tumbia N, Ashcroft GP. Convection warmers: a possible source of contamination in laminar airflow operating theatres? *J Hosp Infect* 2002;52:171-4.
21. Zink RS, Iazzo PA. Convective warming therapy does not increase the risk of wound contamination in the operating room. *Anesth Analg* 1993;76:50-3.
22. Weirich TL. Hypothermia/warming protocols: why are they not widely used in the OR? *AORN J* 2008;87:333-44.
23. Wong PF, Kumar S, Bohra A, Whetter D, Leaper DJ. Randomized clinical trial of perioperative systemic warming in major elective abdominal surgery. *Br J Surg* 2007;94:421-6.
24. Wong PF, Kumar S, Leaper DJ. Systemic warming as an adjunct to resuscitation in peritonitis: a pilot, randomized controlled trial. *Surg Infect (Larchmt)* 2007;8:387-95.
25. Ng V, Lai A, Ho V. Comparison of forced-air warming and electric heating pad for maintenance of body temperature during total knee replacement. *Anaesthesia* 2006;61:1100-4.
26. Janke EL, Pilkington SN, Smith DC. Evaluation of two warming systems after cardiopulmonary bypass. *Br J Anaesth* 1996;77:268-70.
27. Kimberger O, Held C, Stadelmann K, Mayer N, Hunkeler C, Sessler DI, et al. Resistive polymer versus forced-air warming: comparable heat transfer and core rewarming rates in volunteers. *Anesth Analg* 2008;107:1621-6.
28. Negishi C, Hasegawa K, Mukai S, Nakagawa F, Ozaki M, Sessler DI. Resistive-heating and forced-air warming are comparably effective. *Anesth Analg* 2003;96:1683-7.
29. Matsuzaki Y, Matsukawa T, Ohki K, Yamamoto Y, Nakamura M, Oshibuchi T. Warming by resistive heating maintains perioperative normothermia as well as forced-air heating. *Br J Anaesth* 2003;90:689-91.
30. Glor M. Electrostatic ignition hazards in the process industry. *J Electrostat* 2005;63:447-53.
31. Noble WC, Davies RR. Studies on the dispersal of staphylococci. *J Clin Pathol* 1965;18:16-9.
32. Noble WC, Lidwell OM, Kingston D. The size distribution of airborne particles carrying micro-organisms. *J Hyg (Lond)* 1963;61:385-91.
33. Mackintosh CA, Lidwell OM, Towers AG, Marples RR. The dimensions of skin fragments dispersed into the air during activity. *J Hyg (Lond)* 1978;81:471-9.
34. Jensen PA, Schafer MP. Sampling and characterization of bioaerosols. In: NIOSH manual of analytical methods. Atlanta, GA: Centers for Disease Control and Prevention; 1998. p. 82-112.
35. Hamblen DL. Surgical management of the infected arthroplasty. *J Hosp Infect* 1988;11(Suppl C):48-56.
36. US Food and Drug Administration. Labeling reusable medical devices for reprocessing in healthcare facilities. Available from: <http://www.fda.gov/>. Accessed January 25, 2010.
37. Health Canada. Draft guidance document: information to be provided by manufacturers for the reprocessing and sterilization of reusable medical devices. Available from: http://www.hc-sc.gc.ca/dhp-mps/md-im/applc-demanded/guide-ld/md_dgd_manrep_im_eld_fabret-eng.php. Accessed January 25, 2010.
38. Directive C. 93/42/EEC of 14 June 1993 concerning medical devices. *Official Journal of the European Communities* 1993;169:1-43.
39. Harper CM, Andrzejowski JC, Alexander R. NICE and warm. *Br J Anaesth* 2008;101:293-5.
40. World Health Organization. Safe surgery saves lives. Available from: <http://www.who.int/patientsafety/safesurgery/en/>. Accessed January 25, 2010.